

8-Channel White LED Driver IC Solution with Full LED Current and Timing Control for Edge-Lit LCD Screens



General Description

The AHK2417E is a highly integrated, high efficiency white LED edge back-light solution for large size LCD panels used in LCD TVs. The device operates from a regulated 12V or 24V DC power supply.

Utilizing external high voltage power MOSFETs, the AHK2417E can drive a large number of serial connected LEDs with up to 100mA per channel.

Eight precision current sink devices allow the current in each MOSFET to be regulated to within $\pm 2.5\%$ accuracy and $\pm 2.0\%$ matching. This eliminates the need for low-resistance, high-tolerance, expensive sense resistors. Feedback from each current sink is fed back to the high voltage boost converter to ensure the optimum voltage is applied to the LED strings.

A high speed, SPI compatible interface allows fast, independent digital control of each current sink programmed to a maximum value using an external resistor. An 8-Bit Dot Correction register compensates for variations in LED brightness during LCD setup, while two 12-Bit registers control the grayscale current and delay time. Channel ON/OFF control is also included. The Grayscale PWM clock is internally generated or can be externally supplied.

Fault handling and detailed reporting is handled by the SPI bus, while a fault is indicated via an open drain fault pin. The system monitors open or short circuit LEDs, and over-voltage, over-current and over-temperature protection.

The AHK2417E is available in a Pb-free, thermally enhanced 32-pin 7x7mm E-LQFP package, with an 0.8mm pitch for single sided printed circuit boards.

Features

- 8 LED Current Sinks with up to 100mA/ch
 - $\pm 2.5\%$ Accuracy (60mA)
 - $\pm 2.0\%$ Matching (60mA)
- Interface to external high voltage MOSFET
- SPI Interface
 - Digitally Programmable Individual Channels
 - Up to 30MHz Clock Speed)
- Data synchronized to VSYNC
- VSYNC Derived Internal Oscillator
- VSYNC PWM and Delay Synchronization
 - Up to 128 Current Sinks
- Soft-Start to Minimize Inrush Current
- E-LQFP77-32 Low Profile Package with 0.8mm pitch
- -40°C to +85°C Temperature Range

Highlights

Efficient	No external high tolerance, expensive sense resistors required
Flexible	8 channels per IC, minimizing the number of ICs in a system Use of external high voltage MOSFETs allows any number of LEDs to be connected in parallel
Easy	High speed SPI bus interface with latch featuring 12-bit control for Grayscale current, channel delay and 8-bit DOT correction simplifying screen calibration and operation
Safe	Integrated fault protection for shorted & open circuit LEDs, over-current, over-voltage and over-temperature protection with fault reporting

8-Channel White LED Driver IC Solution with Full LED Current and Timing Control for Edge-Lit LCD Screens

Efficient

The internal current sinks contain a sensing element and eliminate the need for expensive, low-resistance, high-tolerance sense resistors. This enables each output to handle 100mA/channel LED current with 2.5% accuracy and 2.0% matching. The high output current and accuracy reduces the LCD calibration time during production and also improves the picture quality when in use. Competitor products that use external resistors to sense the LED current are normally specified at 25° C and ignore the tolerance of the ballast resistor.

Flexible

Each IC consists of 8 channels. Many edge-lit LCD panels contain anywhere between two and eight lighting bars per panel. Depending upon the LEDs required for each lighting bar, the AHK2417E can drive eight bars, reducing the overall cost of the system. For applications where higher brightness (current) LEDs are used, outputs can be connected in parallel to double or even treble the current output.

External High Voltage MOSFETs are used to protect the current sinks from high voltage should the entire LED string short circuit. This allows many LEDs to be connected in series with good reliability. Bipolar transistors may also be used.

Easy

Screen calibration and operation are simplified by a high speed SPI bus interface with 12-Bit control for Grayscale current, channel delay and 8-Bit DOT correction. The high speed bus allows control of up to 256 strings of LEDs at once. DOT correction can be adjusted during LCD calibration and LED brightness can be controlled according to the image displayed. The 12-Bit delay function can compensate for transmission delay effects when controlling LEDs from one end of an LCD to the other. 42" or 50" is a long way to travel. Data entered into the registers is not acted upon until the rising edge of V_{SYNC} to eliminate any potential flicker issues.

Safe

The AHK2417E includes integrated fault protection for shorted & open circuit LEDs, and over-current, over-voltage and over-temperature protection with fault reporting to protect the device from the hostile environment of an LCD TV chassis. In many of these TVs the ambient temperature inside the TV can rise to almost 60° C, so any fault conditions can be catastrophic. The most unique feature of the fault protection is the early warning over-temperature protection where the system gets a pre-warning that unless something is done to reduce the heat generated in the system, the IC will shut down. The system can then decide on a course of action; to reduce the current in the LEDs, shut down the IC or allow the IC to operate as long as it can before shutting down.

Application Diagram

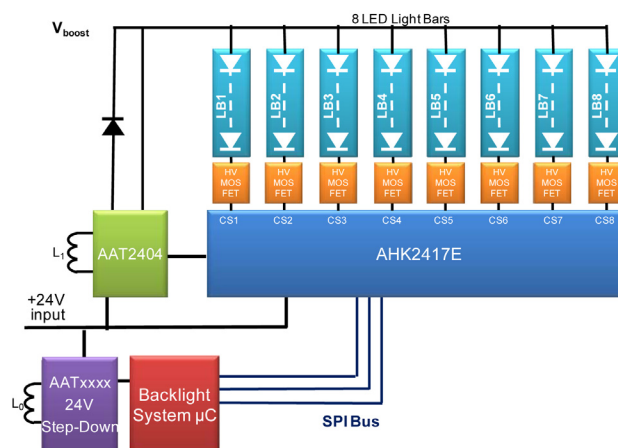

Part Number	Ordering Information
Part Ordering Number	AHK2417EISD-T1
Evaluation Board	AHK2417EISD-DB1
http://www.analogictech.com/contactus/ordersamples.php	